

Modular Cooking Range Line 900XP 400mm Electric Fry Top, Ribbed Brushed Chrome Plate



391356 (E9IILDAOMCA)

Half module electric Fry Top with ribbed brushed chrome cooking Plate, sloped, thermostatic control, scraper included

Short Form Specification

Item No. _____

Ribbed cooking surface in brushed chrome. Temperature range from 120°C to 280°C. To be installed on open base installations, bridging supports or cantilever systems. Removable drawer below the cooking surface for the collection of grease and fat. Body and work top of unit entirely in stainless steel with Scotch Brite finish. Extra strength work top in heavy duty 2 mm stainless steel. Right-angled side edges to allow flush-fitting junction between units.

Main Features

- Unit to be mounted on stainless steel feet with height adjustment up to 50 mm. Unit can be easily mounted on cantilever systems.
- Large drain hole on cooking surface permits the draining of fat into large 1,5 liter collector placed under the cooking surface.
- Stainless steel high splash guards on the rear and sides of cooking surface. Splash guards can be easily removed for cleaning and are dishwasher-safe.
- The special design of the control knob system guarantees against water infiltration.
- IPX5 water protection.
- Temperature range from 120° up to 280°C.
- Rough brushed chrome surface is highly resistant to scratches and facilitates cleaning operations at the end of the day.
- Scraper for ribbed plate included as standard.
- Suitable for countertop installation.

Construction

- Cooking surface completely ribbed.
- Unit is 930 mm deep to give a larger working surface area.
- All exterior panels in Stainless Steel with Scotch Brite finishing.
- AISI 304 stainless steel worktop, 2mm thick.
- Model has right-angled side edges to allow flush fitting joints between units, eliminating gaps and possible dirt traps.
- Cooking surface 15mm thick brushed chrome for optimum grilling results and ease of use.

Included Accessories

- 1 of Scraper for ribbed plate fry tops - kit includes knife blades for both smooth and ribbed surface PNC 206420

Optional Accessories

- Junction sealing kit PNC 206086
- Draught diverter, 120 mm diameter PNC 206126
- Matching ring for flue condenser, 120 mm diameter PNC 206127
- Draught diverter, 150 mm diameter PNC 206132
- Matching ring for flue condenser, 150 mm diameter PNC 206133
- Kit 4 wheels - 2 swivelling with brake - it is mandatory to install Base support and wheels PNC 206135
- Flanged feet kit PNC 206136
- Support for bridge type installation, 800mm PNC 206137
- Support for bridge type installation, 1000mm PNC 206138
- Support for bridge type installation, 1200mm PNC 206139

APPROVAL: _____



• Support for bridge type installation, 1400mm	PNC 206140	<input type="checkbox"/>	• 2 side covering panels for free standing appliances	PNC 216134	<input type="checkbox"/>
• Support for bridge type installation, 1600mm	PNC 206141	<input type="checkbox"/>	• Water drain for full module fry tops	PNC 216153	<input type="checkbox"/>
• Frontal kicking strip for concrete installation, 800mm	PNC 206148	<input type="checkbox"/>	• Large handrail - portioning shelf, 400mm	PNC 216185	<input type="checkbox"/>
• Frontal kicking strip for concrete installation, 1000mm	PNC 206150	<input type="checkbox"/>	• Large handrail - portioning shelf, 800mm	PNC 216186	<input type="checkbox"/>
• Frontal kicking strip for concrete installation, 1200mm	PNC 206151	<input type="checkbox"/>	• 2 side covering panels for top appliances	PNC 216278	<input type="checkbox"/>
• Frontal kicking strip for concrete installation, 1600mm	PNC 206152	<input type="checkbox"/>	• Pressure regulator for gas units	PNC 927225	<input type="checkbox"/>
• Water drain for half module fry tops	PNC 206153	<input type="checkbox"/>			
• Support for bridge type installation, 400mm	PNC 206154	<input type="checkbox"/>			
• Pair of side kicking strips for concrete installation	PNC 206157	<input type="checkbox"/>			
• Frontal kicking strip, 800mm (not for refr-freezer base)	PNC 206176	<input type="checkbox"/>			
• Frontal kicking strip, 1000mm (not for refr-freezer base)	PNC 206177	<input type="checkbox"/>			
• Frontal kicking strip, 1200mm (not for refr-freezer base)	PNC 206178	<input type="checkbox"/>			
• Frontal kicking strip, 1600mm (not for refr-freezer base)	PNC 206179	<input type="checkbox"/>			
• Pair of side kicking strips (not for refr-freezer base)	PNC 206180	<input type="checkbox"/>			
• 2 panels for service duct for single installation	PNC 206181	<input type="checkbox"/>			
• 2 panels for service duct for back to back installation	PNC 206202	<input type="checkbox"/>			
• Kit 4 feet for concrete installation (not for 900 line free standing grill)	PNC 206210	<input type="checkbox"/>			
• Flue condenser for 1 module, 150 mm diameter	PNC 206246	<input type="checkbox"/>			
• Chimney upstand, 800mm	PNC 206304	<input type="checkbox"/>			
• Back handrail 800 mm	PNC 206308	<input type="checkbox"/>			
• Back handrail 1200 mm	PNC 206309	<input type="checkbox"/>			
• Grease/oil kit container for 700 line frytops (half and module) and 900 line frytops (module)	PNC 206346	<input type="checkbox"/>			
• Base support for feet or wheels - 800mm (700/900)	PNC 206367	<input type="checkbox"/>			
• Base support for feet or wheels - 1200mm (700/900)	PNC 206368	<input type="checkbox"/>			
• Base support for feet or wheels - 1600mm (700/900)	PNC 206369	<input type="checkbox"/>			
• Base support for feet or wheels - 2000mm (700/900)	PNC 206370	<input type="checkbox"/>			
• Rear paneling - 800mm (700/900)	PNC 206374	<input type="checkbox"/>			
• Rear paneling - 1000mm (700/900)	PNC 206375	<input type="checkbox"/>			
• Rear paneling - 1200mm (700/900)	PNC 206376	<input type="checkbox"/>			
• Chimney grid net, 400mm (700XP/900)	PNC 206400	<input type="checkbox"/>			
• Scraper for ribbed plate fry tops - kit includes knife blades for both smooth and ribbed surface	PNC 206420	<input type="checkbox"/>			
• Cloche for fry tops	PNC 206455	<input type="checkbox"/>			
• Side handrail-right/left hand (900XP)	PNC 216044	<input type="checkbox"/>			
• Frontal handrail, 400mm	PNC 216046	<input type="checkbox"/>			
• Frontal handrail, 800mm	PNC 216047	<input type="checkbox"/>			
• Frontal handrail, 1200mm	PNC 216049	<input type="checkbox"/>			
• Frontal handrail, 1600mm	PNC 216050	<input type="checkbox"/>			

Front

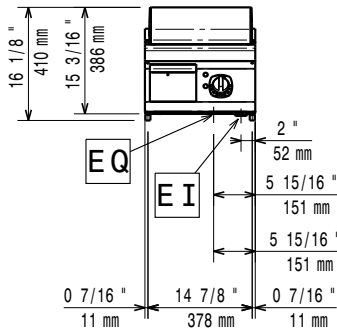

Side

- EI = Electrical inlet (power)
- EQ = Equipotential screw

Top

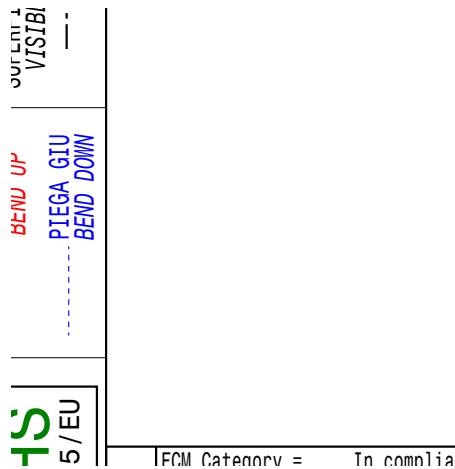



THIS DRAWING CONTAINS CONFIDENTIAL INFORMATION
ELECTROLUX PROFESSIONAL Vallenoncello, Italy w
it may not be copied, shown or handed to a thi
and it is to be returned promptly upon reques
PROFESSIONAL Vallenoncello, Italy which is res

Front

Side

EI = Electrical inlet (power)
EQ = Equipotential screw

TS
5/EU
BEND UP
PIEGA GIU
BEND DOWN
VISIBILI
OUTLINE

FCM Category = In compliance

Top



Electrolux
PROFESSIONAL

Modular Cooking Range Line 900XP 400mm Electric Fry Top, Ribbed Brushed Chrome Plate

Electric

Supply voltage:
391356 (E9IILDAOMCA) 380-400 V/3 ph/50-60 Hz
Total Watts: 7.5 kW

Key Information:

External dimensions, Width: 400 mm
External dimensions, Depth: 930 mm
External dimensions, Height: 250 mm
Net weight: 55 kg
Shipping weight: 53 kg
Shipping height: 580 mm
Shipping width: 470 mm
Shipping depth: 1020 mm
Shipping volume: 0.28 m³

If appliance is set up or next to or against temperature sensitive furniture or similar, a safety gap of approximately 150 mm should be maintained or some form of heat insulation fitted.



Modular Cooking Range Line
900XP 400mm Electric Fry Top, Ribbed Brushed Chrome Plate

The company reserves the right to make modifications to the products without prior notice. All information correct at time of printing.

2022.05.06